

B

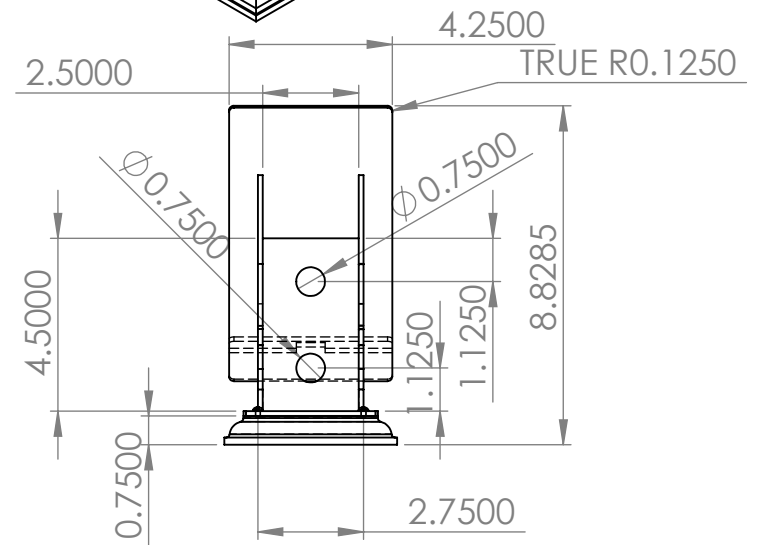
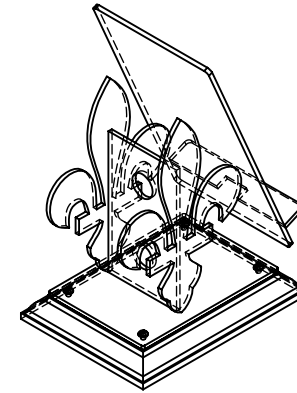
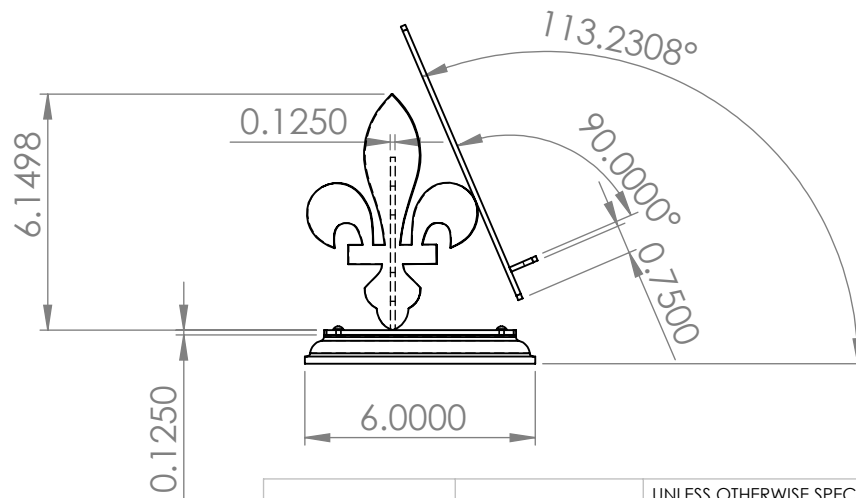
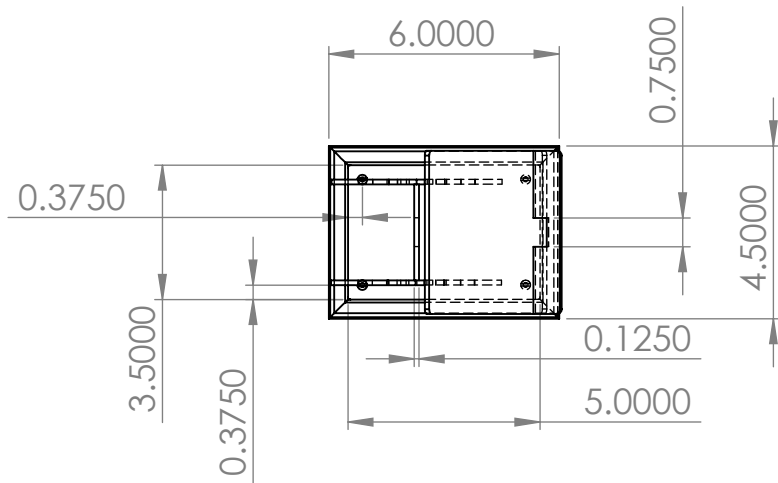

B

A

PROPRIETARY AND CONFIDENTIAL
THE INFORMATION CONTAINED IN THIS
DRAWING IS THE SOLE PROPERTY OF
PLATT MFG. ANY REPRODUCTION IN PART
OR AS A WHOLE WITHOUT THE WRITTEN
PERMISSION OF PLATT MFG IS
PROHIBITED.

		UNLESS OTHERWISE SPECIFIED:	NAME	DATE
		DIMENSIONS ARE IN INCHES	DRAWN	R. PLATT 9/16/16
		TOLERANCES:	CHECKED	R. PLATT 9/17/16
		FRACTIONAL ±	ENG APPR.	R. PLATT 9/17/16
		ANGULAR: MACH ± BEND ±	MFG APPR.	R. PLATT 9/19/16
		TWO PLACE DECIMAL ±	Q.A.	END USER TBD
		THREE PLACE DECIMAL ±	COMMENTS:	
		INTERPRET GEOMETRIC TOLERANCING PER:	USE HARDWOOD OF CHOICE AND 1/8" HOT ROLLED PLATE FROM LEAST EXPENSIVE SUPPLIER. LOCAL SOURCE ON CLEAR ENAMEL PAINT.	
		MATERIAL:	HARDWOOD & HOT ROLLED STEEL	
NEXT ASSY	USED ON	FINISH:	SANDDED GLOSS ENAMEL FINISH.	
APPLICATION		DO NOT SCALE DRAWING		

Platt MFG

TITLE:

FLEUR DIS LI PHONE STAND

SIZE	DWG. NO.	REV
A	FDL-PS-001	
SCALE: 1:5	SHEET 1 OF 1	